

LHR Series High Rate LHR12255W(12V255W)

Specifications

Rated Voltage	12V	
Nominal Rate (W_{15} , 1.67V/cell)	255W	
Nominal Capacity(C_{10} , 1.80V/cell)	70Ah	
Dimension	Length	348±2mm (13.70 inches)
	Width	167±2mm (6.57 inches)
	Container Height	178±2mm (7.01 inches)
	Total Height	178±2mm (7.01 inches)
Approx. Weight	21.6 Kg (47.6 lbs)	
Terminal	M6	
Container Material	ABS(UL94 V-0)	
Rated Capacity (25°C)	70.0 Ah	(10hr, 7.00A, 1.80V/cell)
	67.2 Ah	(8hr, 8.40A, 1.80V/cell)
	61.5 Ah	(5hr, 12.3A, 1.75V/cell)
	55.8 Ah	(3hr, 18.6A, 1.75V/cell)
	48.0 Ah	
Max. Discharge Current	900A	
Internal Resistance (25°C)	Approx. 6.6mΩ	
Operating Temp. Range	Discharge	-20 ~ 55°C (4 ~ 131°F)
	Charge	0 ~ 40°C (32 ~ 104°F)
	Storage	-15 ~ 50°C (5 ~ 122°F)
Nominal Operating Temp. Range	25±3°C (77±5°F)	
Max. Charging Current(25°C)	17.5A	
Charge voltage(25°C)	Float	13.5V
	Temp. Coefficient	-3mV/cell/°C
	Equalization	14.1~14.4V
Effect of temp. to Capacity	40°C (104°F)	106%
	25°C (77°F)	100%
	0°C (32°F)	86%
Self Discharge	≤3%/month @ 25°C	

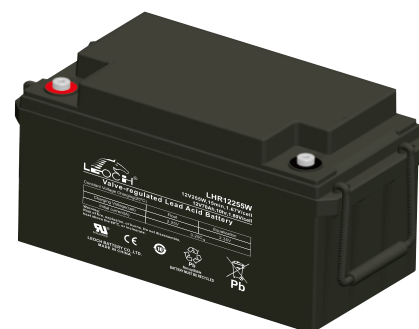

Layout

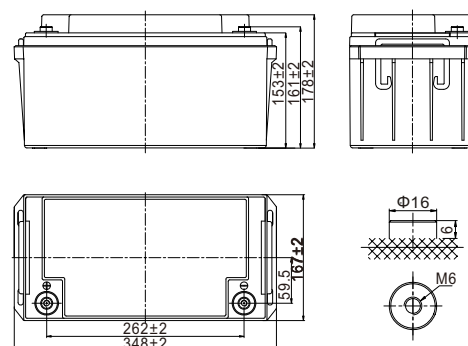

Constant Current Discharge (Amperes) at 25 °C (77°F)

F.V/Time	5min	10min	15min	20min	30min	45min	1h	1.5h	2h	3h	4h	5h	8h	10h
1.85V/cell	156.1	116.5	97.1	81.6	62.7	46.8	39.5	29.6	23.7	16.7	13.3	11.1	7.80	6.60
1.80V/cell	182.0	137.4	112.9	94.0	70.9	52.3	43.7	32.4	25.8	18.1	14.3	12.0	8.40	7.00
1.75V/cell	198.6	147.3	119.4	98.6	74.1	54.4	45.4	33.5	26.6	18.6	14.7	12.3	8.60	7.10
1.70V/cell	215.1	157.1	126.2	103.8	77.3	56.5	47.0	34.7	27.5	19.1	15.1	12.5	8.70	7.20
1.67V/cell	224.5	162.9	130.2	106.7	79.3	57.8	48.0	35.3	27.9	19.4	15.3	12.7	8.80	7.30
1.60V/cell	247.5	176.3	139.5	113.6	83.8	60.8	50.3	36.8	29.1	20.1	15.8	13.1	9.00	7.40

Constant Power Discharge (Watts/cell) at 25 °C (77°F)

F.V/Time	5min	10min	15min	20min	30min	45min	1h	1.5h	2h	3h	4h	5h	8h	10h
1.85V/cell	301.4	225.9	189.1	159.4	135.2	98.9	78.6	57.8	46.4	35.1	28.0	23.5	16.6	13.9
1.80V/cell	349.5	265.3	219.2	183.1	142.6	105.7	84.4	61.0	49.2	36.7	30.1	25.2	17.7	14.8
1.75V/cell	384.2	283.0	232.7	191.0	147.8	109.2	86.9	64.0	51.4	38.0	30.7	25.7	18.0	15.0
1.70V/cell	409.3	304.2	246.5	203.9	152.9	112.4	89.5	66.4	52.8	39.1	31.4	26.2	18.3	15.2
1.67V/cell	418.3	312.9	255.0	209.4	158.6	114.4	90.9	67.3	53.5	39.8	31.7	26.5	18.5	15.4
1.60V/cell	424.6	331.7	265.9	223.3	162.6	119.0	94.5	69.3	55.1	40.4	32.6	27.1	18.9	15.6

LHR Series High Rate LHR12255W(12V255W)

Applications

- UPS
- Hospitals & Testing Laboratories
- Emergency Power Supply
- Industrial Process Control Facilities
- Banks & Financial Markets
- Data & Network Operation Centers

General Features

- ABS material: UL94 V-0
- Oxygen recombination efficiency: $\geq 98\%$
- High quality AGM separator: extend cycle life and prevent micro short circuit
- Unique vent valve design: reduce water losing and prevent air/spark going inside
- PbCaSn alloy for plate grids: less gassing, less self-discharging

Standards

- Compliance with IEC 60896 standards
- Classified as "Long Life" according to Eurobat
- CE, UL Certified
- Manufactured in Leoch@IATF16949, OHSAS 18001, ISO 9001 and ISO 14001 certified production facilities

Discharge Characteristics

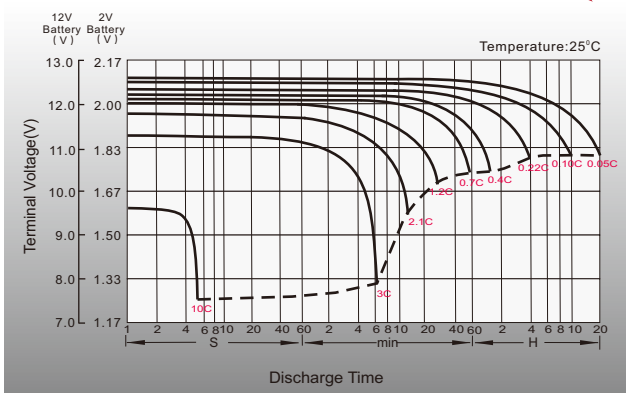

Float Charging Characteristics

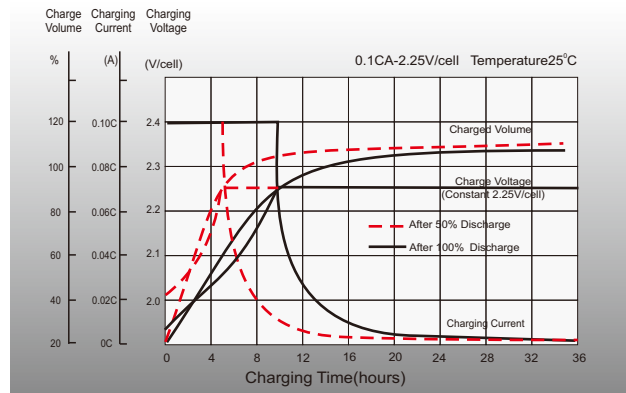

Temperature Effects in Relation to Battery Capacity

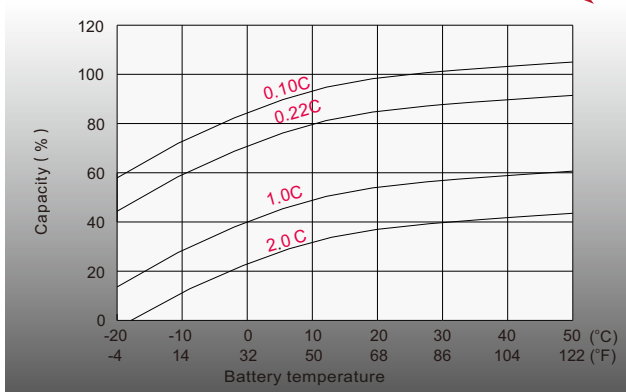

Temperature Effects on Long Term Float Life

